

# INSTALLATION MANUAL:

***COR-1709101 / 1809101***

Jeep Wrangler OVERLAND+ and PREMIUM  
Short Front Upper Control Arms (2018+ JL/JT)



# INCLUDED ITEMS

## 1709101 Jeep Wrangler OVERLAND+ Short Front Upper Control Arms - (2018+, JL/JT)

QTY	Part Number	Description	Class/Grade
2	1709101	Short Front Upper Control Arms	N/A

## 1809101 Jeep Wrangler PREMIUM Short Front Upper Control Arms - (2018+, JL/JT)

QTY	Part Number	Description	Class/Grade
2	1809101	Short Front Upper Control Arms	N/A

### Product Notes and Features:

#### OVERLAND+ Series:

- Maintenance-free, dual-durometer design isolates road noise for a quieter ride.
- Self-centering with 26.6 degrees of total articulation, ensuring smooth suspension movement.
- Teflon-infused inner surface acts as a bearing for long-lasting performance.

#### PREMIUM Series:

- Reliable, greaseable, and rebuildable design for unmatched comfort and reliability
- 40 degrees of total misalignment, performing best in off-road conditions
- Smooth and quiet performance

## COR-1709101



## COR-1809101



# CONTROL ARM OVERVIEW

\*\*\*Please review the following information so you can become familiar with our purchasable options\*\*\*



## OVERLAND PLUS

Designed for the daily driver/weekend warrior. Features dual-durometer, maintenance-free bushings for comfort on-road and capability on the trails. One of our two available suspension systems that utilize a unique arm design for perfecting suspension geometry. Fully adjustable, 100% bolt on, and Made-In-The-USA with a Lifetime Warranty.



## PREMIUM SERIES

Designed for the off-road enthusiast. Features both maintenance-free bushings and forged Johnny Joint adjusters for maximum versatility and flex. One of our two available suspension systems that utilize a unique arm design for perfecting suspension geometry. Fully adjustable, 100% bolt on, and Made-In-The-USA with a Lifetime Warranty.

# DISCLAIMER

## WARNING:

Suspension systems and their components are designed to enhance your vehicle's off-road performance. This may cause your vehicle to handle differently, on and off-road. Always wear your seatbelt and take extra care when driving a modified vehicle. Failure to do so can result in loss of control which may result in a rollover causing serious injury, or even death to the driver and/or passengers of the vehicle. Regular maintenance and consistent inspections are required to keep your modified vehicle safe and functioning properly. These suspension systems and any components should be installed by certified technicians only. Attempts to install these products without proper knowledge can lead to poor performance, or possible failure, which may jeopardize the safety of the vehicle and its passengers. The installer is responsible for proper installation ensuring a safe and properly functioning vehicle. Take extra care when operating a modified vehicle and thoroughly inspect your vehicle before and after every off-road use.

Read the instruction set in its entirety before attempting the installation.

## NOTE:

This product may require general welding, fabrication, and automotive mechanic skills. Welding should only be done by a competent welder. Clayton Off Road implies no guarantees or warranties and is not liable for improper installation. Some grinding and fitment may be required when installing this product. Every vehicle varies slightly, and some fabrication and/or modification may be required.

## ATTENTION:

It is the customer's responsibility to thoroughly inspect all received parts to ensure they are assembled correctly and fully welded. Please carefully examine all weld seams and verify that bolt-through holes are properly aligned. Some Clayton Off Road products are permanent, non-removable, weld-on solutions. **If a defect or issue is found after installation, especially with permanent weld-on components, it may be difficult or impossible to correct.** Inspecting the part(s) received beforehand helps prevent unnecessary and avoidable complications.

## ATTENTION: TORQUE SPECIFICATION

When working on any vehicle, it is good practice to torque suspension/weight-bearing components while the vehicle is resting under its load. This instruction set, as well as any other Clayton Off Road instruction set, assumes the installer will tighten any suspension-related components properly, to the recommended torque specification, when the vehicle is resting safely under its own weight.

# INSTALLATION INSTRUCTIONS

\*\*\*Take this product to a licensed professional if you are hesitant about the installation process!\*\*\*

**The following instructions apply to the listed components below:**

- Short Front Upper Control Arms (OVERLAND+ or PREMIUM)

This guide applies to both OVERLAND+ or PREMIUM Control Arms, unless noted otherwise.

We strongly recommend having basic mechanic's hand tools, sockets, wrenches, vehicle jacks and stands, and other common tools readily available. Installing an aftermarket lift kit is a detailed process, and having the right tools on hand will ensure a smoother installation.

**As always, feel free to contact us anytime during your installation - you can count on us to help!**

## COR-1709101

1709101 Installation Tools Required:

- 10, 18mm socket/wrench
- Impact drill
- Vehicle jack and stands
- Torque wrench
- Large adjustable wrench (OR 1-1/2")

## COR-1809101

1809101 Installation Tools Required:

- 10, 18mm socket/wrench
- Impact drill
- Vehicle jack and stands
- Torque wrench
- Large adjustable wrench (OR 1-1/2")

# CONTROL ARM LENGTHS

Please refer to the table below for minimum, maximum, and recommended control arm lengths. These lengths are recommendations and should only serve as a starting point for axle positioning and dialing in pinion/caster angle. **The following measurements are given as “eye-to-eye” lengths (center-to-center of joints). The desired caster angle should be somewhere between 5.5 - 6 degrees.**

Please note that your exact arm length will vary by lift height. Refer to Table 2 for recommended starting points based off your lift height. These are **NOT** intended as final measurements. Due to many variables, final adjustments should be made once all components are installed, then fine-tuned for your specific vehicle.

Table 1: COR-1709101 / 1809101 Minimum and Maximum Arm Lengths

Control Arm Type / Series	Minimum	Maximum
1709101 OVERLAND+ Short Front Upper Arms	19 - 3/4"	21 - 1/8"
1809101 PREMIUM Short Front Upper Arms	19 - 5/8"	22 - 1/4"

Table 2: COR-1709101 / 1809101 Arm Lengths by Lift Height

Vehicle Make/Model/Year	1.5" Lift	2.5" Lift	3.5" Lift	4.5" Lift
4-Door Jeep JL/JT (2018+)	20 - 3/16"	20 - 1/4"	20 - 3/8"	20 - 9/16"
2-Door Jeep JL (2018+)	20 - 3/16"	20 - 1/4"	20 - 3/8"	20 - 9/16"

# INSTALLATION INSTRUCTIONS

\*\*\*Take this product to a licensed professional if you are hesitant about the installation process!\*\*\*

1. Use a vehicle jack to lift the front axle off the ground. Support the axle on either side with an adjustable, self-locking jack stand. A jack stand supporting the pinion works well to prevent any rotation. You may want to chock the tires if performing this installation on the ground.

Remove the heat shields surrounding the upper control arm mounts on both sides of the frame using a 10mm socket. Save the heat shields and hardware. One bolt is located on the side, the other on the top (hidden). The top bolt is hard to get to, so use a small ratchet or ratcheting socket.

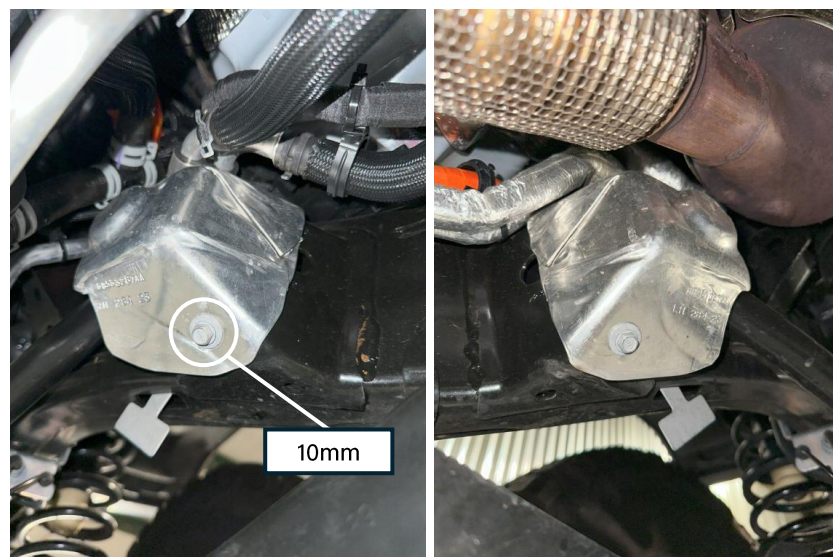

OEM Front upper heat shields to be removed

# INSTALLATION INSTRUCTIONS

**\*\*\*Take this product to a licensed professional if you are hesitant about the installation process!\*\*\***

2. Remove the old upper control arms using an 18mm socket at both the axle and the frame-end. There is a flag nut at the frame-end that will hold the nut in place while you back out the nut. Put all hardware aside, as it will be reused.

When the upper control arms are removed, set the caster to the desired angle by adjusting the height of the jack stand under the pinion.

The exhaust section on some models may prevent the removal of the OEM front upper control arm bolt at the frame-end. We recommend loosening the bolt and bending the exhaust heat shield to slowly pry the bolt out. When reinstalling, flip the bolt around.



OEM Front upper control arm bolt frame and axle (driver-side)

# INSTALLATION INSTRUCTIONS

3. Determine the appropriate length of the new front upper control arms based on your vehicle's ride height and your desired pinion and caster angles. Use the lengths provided at the beginning of these instructions as a starting point.

Adjust the end-forging by screwing it in or out. **Measure the length from eye-to-eye, or center of bushing to center of bushing.** When the desired length is met, spin the jam nut down to the control arm to lock the forging into position.

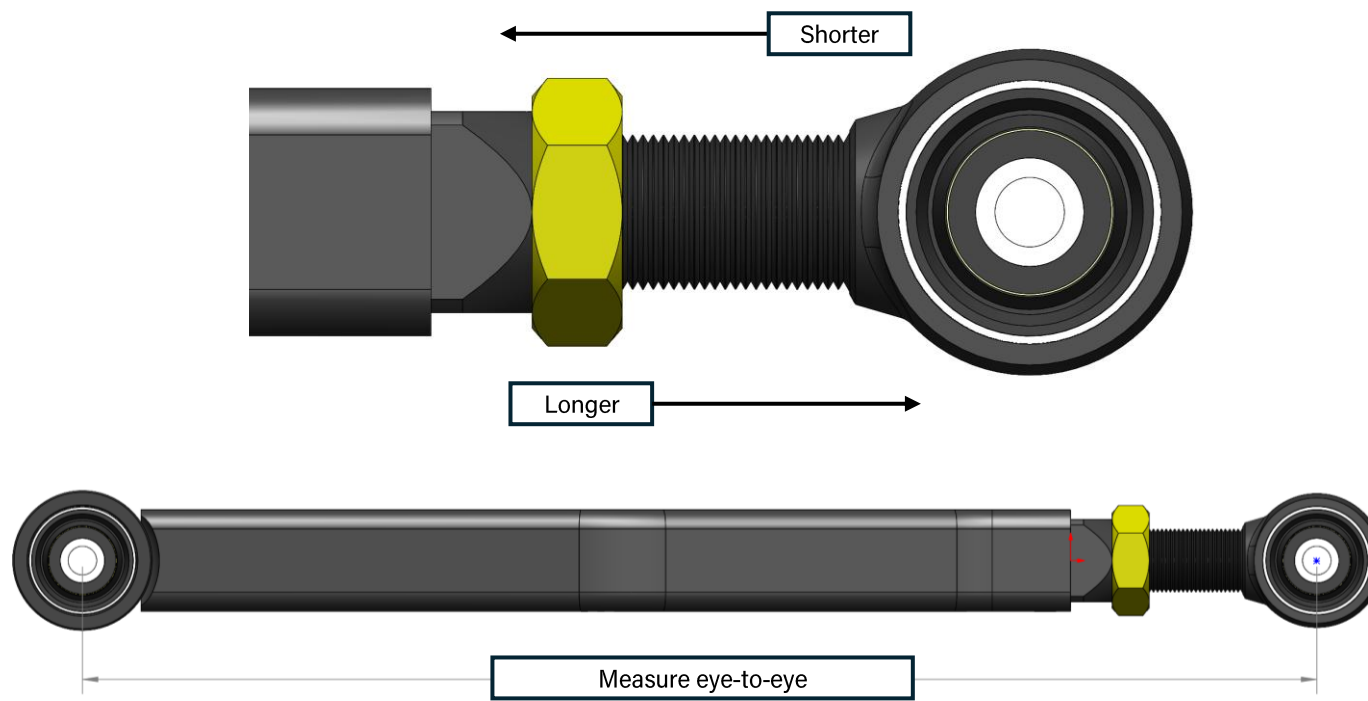

# INSTALLATION INSTRUCTIONS

4. Install the upper control arms at the frame-end. The adjuster should be located at the frame end. The upper control arm should bow away from the frame when used in this application. The Clayton Off-Road Long Arm Kit (JL/JT) uses the same upper control arms, but they will be installed differently. See the Upper Control Arm Quick Guide at the end of these instructions for more details. Use OEM hardware.

Adjust the control arms to length at the axle so that the bolts can easily be installed at the axle-end. Remove the pinion jack stand and check the caster angle. You may need to prop up the pinion again, remove the control arm bolts at the axle, and adjust as needed.

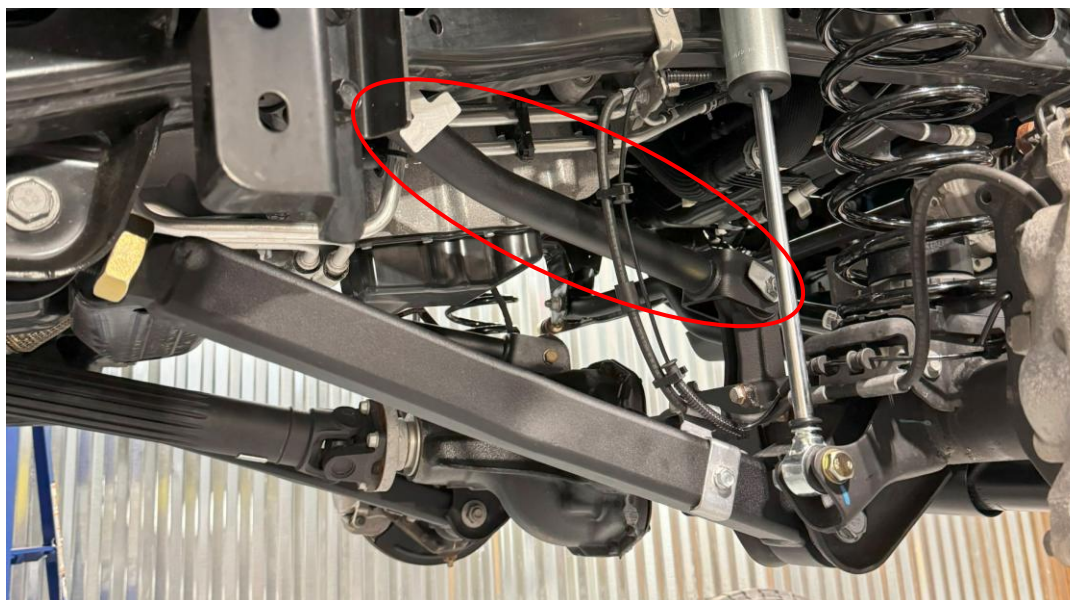

1709101 (OVERLAND+ Series) Front upper control arm installed, passenger-side

# INSTALLATION INSTRUCTIONS

5. Return the vehicle to the ground. Torque both upper control arm bolts on either side to **80 ft-lbs using a torque wrench.**

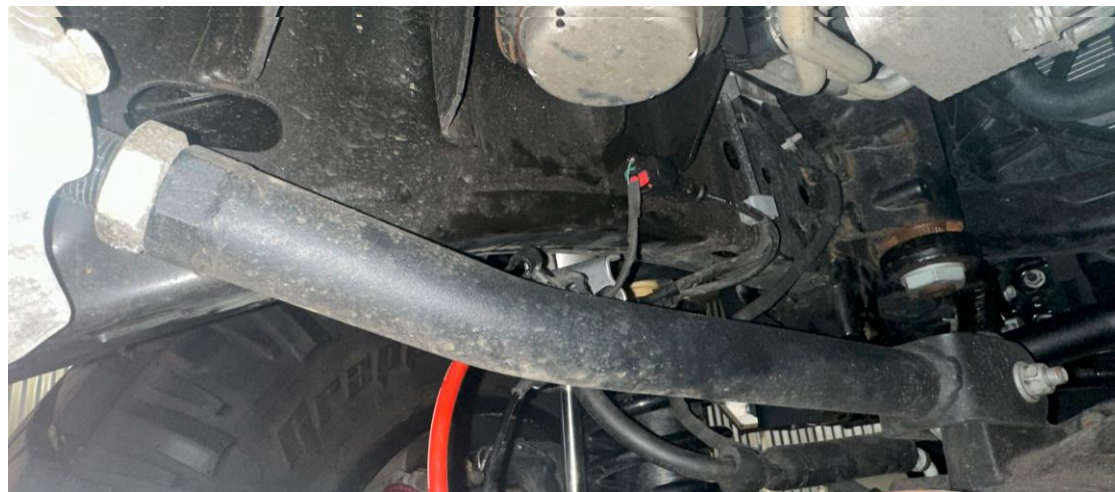

1709101 (OVERLAND+ Series) Front upper control arm installed

# INSTALLATION INSTRUCTIONS

6. Reinstall the upper control arm heat shields using a 10mm socket. Reinstall on both sides

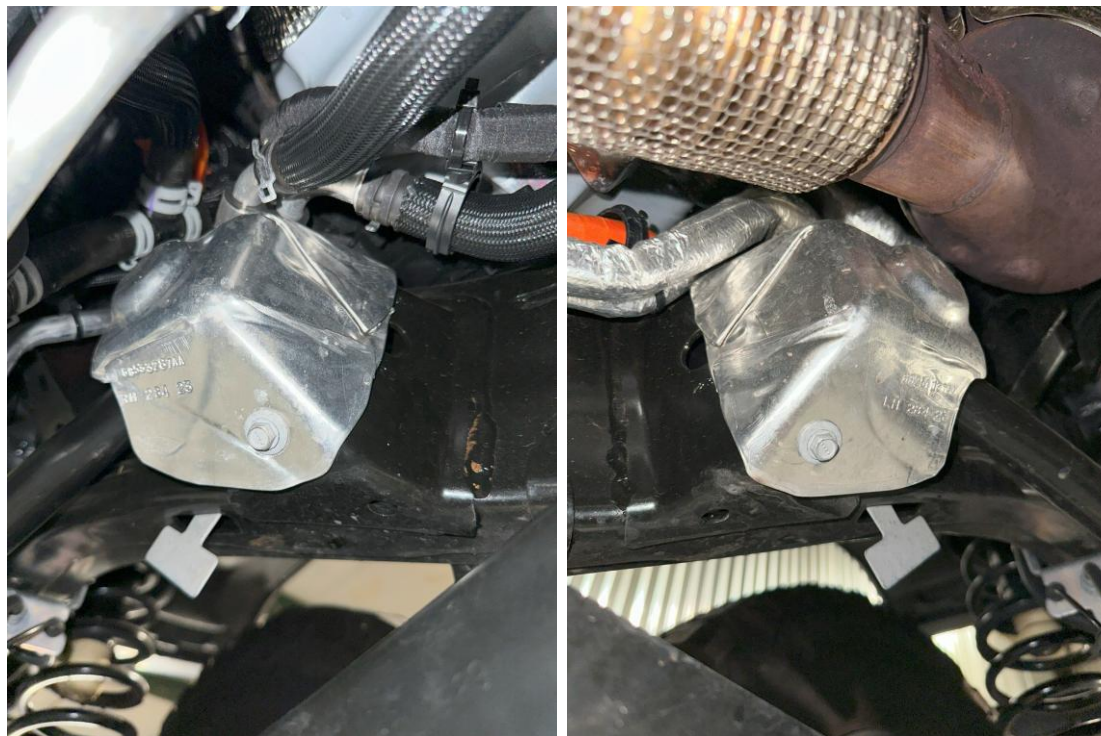

OEM Front upper heat shields reinstalled

# INSTALLATION INSTRUCTIONS

7. Tighten down the jam nuts on the upper and lower control arms. Use a 1-7/8" wrench for the lower control arm jam nuts, and a 1-1/2" wrench for the upper control arm jam nuts. Use a breaker bar to gain additional leverage. Tighten all jam nuts down as tight as humanly possible.

Please note that not all wrenches are created with the same tolerances. If your wrenches are too loose around the jam nut, Clayton Off Road offers tight, wrap-around wrenches for purchase. Please search for the wrenches using the SKU's below.



COR Wrench-ends for control arm jam nuts (COR-2500125, COR-2500100)

# INSTALLATION INSTRUCTIONS

8. The installation is now complete. Please follow the post-installation checklist below before driving your vehicle.



## POST-INSTALLATION CHECKLIST:

- Front upper control arm bolts (axle and frame) are torqued to 80 ft-lbs
- Lug nuts are torqued to manufacturers specification (if removed)
- Jam nuts are jammed down as tight as possible
- Vehicle is properly aligned by a professional for adjusting your caster and aligning suspension



# FRONT CONTROL ARM QUICK GUIDE

\*\*\*Please review the following information so that the control arms are installed in the proper orientation\*\*\*

## SHORT-ARM INSTALL JEEP JL/JT

The front lower control arms are **NOT** side-specific. Mount the adjuster and forging on the frame-side, and the bushing housing on the axle-side (SKU 1709100 or 1809100).

The front upper control arms **ARE** side-specific. **Note the upper arm with the red tag.** It should be installed on the driver-side, with both arms elbow-bends pointing down towards the ground (SKU 1709101/1809101).

## LONG-ARM INSTALL JEEP JL/JT

The front lower control arms **ARE** side-specific. Mount the adjuster and forging on the frame-side and ensure the **radius linkage bracket is pointed towards the center of the vehicle** (SKU 1909010 or 1909210).

The front upper control arms **ARE** side-specific. **Note the upper arm with the red tag.** It should be installed on the passenger side, with the elbow bend pointing up towards the vehicle (SKU 1709101/1809101).

UPPER ARMS - 1709101 or 1809101

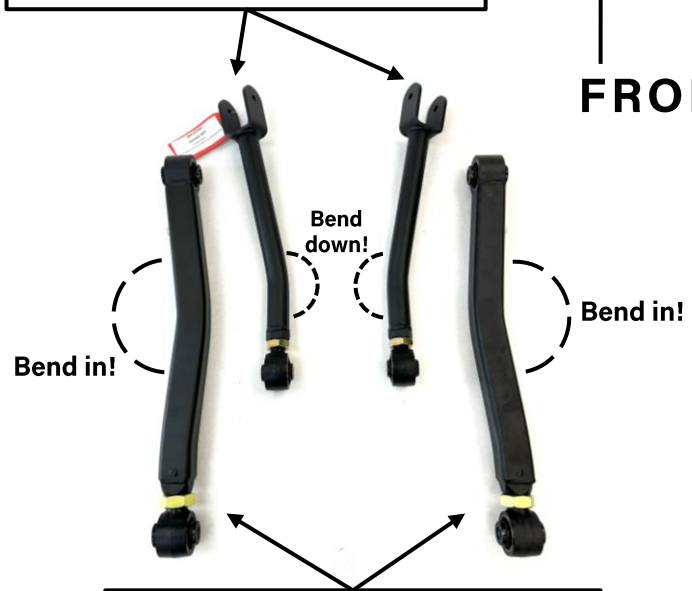

LOWER ARMS - 1709100 or 1809100

FRONT OF VEHICLE

UPPER ARMS - 1709101 or 1809101

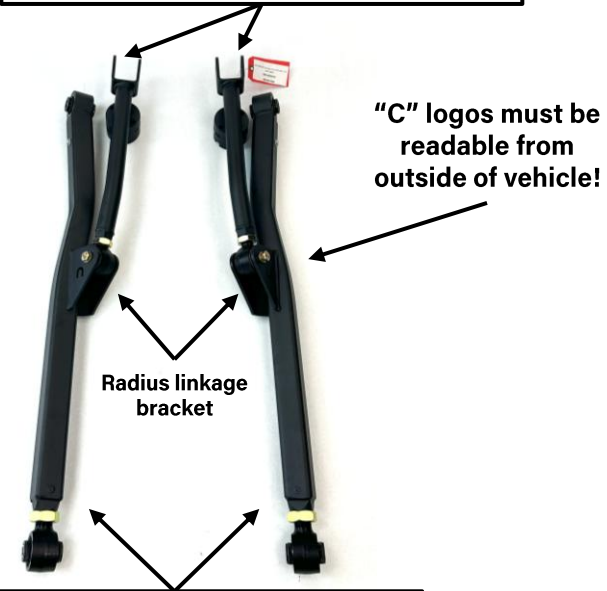

LOWER ARMS - 1909010 or 1909210