

# INSTALLATION MANUAL:

**COR-4500200**

Jeep Wrangler Adjustable Front Track Bar  
(1984-2006, TJ/LJ/XJ/ZJ)



# INCLUDED ITEMS

## 4500200 Jeep Adjustable Front Track Bar - (1984-2006, TJ/LJ/XJ/ZJ)

QTY	Part Number	Description	Class/Grade
1	4500200	Adjustable Front Track Bar	N/A
2	18947	9/16"-18 x 3" Yellow Zinc Finish SAE J429 Hex Cap Screw	Grade 8
4	33818	9/16" Yellow Zinc Finish SAE Flat Washer	Thru-Hardened
2	37310	9/16"-18 Zinc Finish Top Lock Nut	Grade C

### Product Notes and Features:

- Track bar made from 1-3/8" x 5/16" DOM tubing for extra strength and unmatched durability
- GIIRO Joint at the axle and a greaseable, 2.5" Forged Johnny Joint at the frame results in smooth, isolated noise and vibration
- Perfect for TJ/LJs running 4-5" of lift, and XJ/ZJs running 3-6" of lift
- Provided larger than stock 9/16"-18 Grade 8 bolts and hardware for both the axle and frame connection to prevent track bar play and slop
- Drilling is required for proper installation
- **Installing a track bar drop bracket in conjunction with this track bar is recommended for higher lift heights**



# DISCLAIMER

## WARNING:

Suspension systems and their components are designed to enhance your vehicle's off-road performance. This may cause your vehicle to handle differently, on and off-road. Always wear your seatbelt and take extra care when driving a modified vehicle. Failure to do so can result in loss of control which may result in a rollover causing serious injury, or even death to the driver and/or passengers of the vehicle. Regular maintenance and consistent inspections are required to keep your modified vehicle safe and functioning properly. These suspension systems and any components should be installed by certified technicians only. Attempts to install these products without proper knowledge can lead to poor performance, or possible failure, which may jeopardize the safety of the vehicle and its passengers. The installer is responsible for proper installation ensuring a safe and properly functioning vehicle. Take extra care when operating a modified vehicle and thoroughly inspect your vehicle before and after every off-road use.

Read the instruction set in its entirety before attempting the installation.

## NOTE:

This product may require general welding, fabrication, and automotive mechanic skills. Welding should only be done by a competent welder. Clayton Off Road implies no guarantees or warranties and is not liable for improper installation. Some grinding and fitment may be required when installing this product. Every vehicle varies slightly, and some fabrication and/or modification may be required.

## ATTENTION:

It is the customer's responsibility to thoroughly inspect all received parts to ensure they are assembled correctly and fully welded. Please carefully examine all weld seams and verify that bolt-through holes are properly aligned. Some Clayton Off Road products are permanent, non-removable, weld-on solutions. **If a defect or issue is found after installation, especially with permanent weld-on components, it may be difficult or impossible to correct.** Inspecting the part(s) received beforehand helps prevent unnecessary and avoidable complications.

## ATTENTION: TORQUE SPECIFICATION

When working on any vehicle, it is good practice to torque suspension/weight-bearing components while the vehicle is resting under its load. This instruction set, as well as any other Clayton Off Road instruction set, assumes the installer will tighten any suspension-related components properly, to the recommended torque specification, when the vehicle is resting safely under its own weight.

# INSTALLATION INSTRUCTIONS

\*\*\*Take this product to a licensed professional if you are hesitant about the installation process!\*\*\*

The following instructions apply to the listed components below:

- Wrangler Adjustable Front Track Bar with Drop Bracket (1984-2001, XJ/ZJ)

We strongly recommend having basic mechanic's hand tools, sockets, wrenches, vehicle jacks and stands, and other common tools readily available. Installing an aftermarket lift kit is a detailed process, and having the right tools on hand will ensure a smoother installation.

As always, feel free to contact us anytime during your installation - you can count on us to help!

## COR-4500200

### Installation Tools Required:

- 17mm socket/wrench
- 13/16, 7/8" socket/wrench
- 9/16" drill bit and drill
- Adjustable wrench or a 1-1/2" wrench
- Welder
- Torque wrench
- Impact drill

# TRACK BAR LENGTHS

Please refer to the table below for minimum and maximum track bar lengths for this product. These lengths are recommendations and should only serve as limits for axle positioning and dialing in axle track. **The following measurements are given as “eye-to-eye” lengths (center-to-center of joints).**

Please note that your exact track bar length will vary by lift height. You will need to adjust the track bar based off of where the axle sits under the vehicle. Please take care and have patience when aligning the axle track.

Table 1: COR-4500200 Minimum and Maximum Track Bar Lengths

COR Number / Product Name	Minimum	Maximum
4500200 Wrangler Adjustable Front Track Bar	$31 - \frac{1}{8}$ ”	$32 - \frac{3}{16}$ ”

# INSTALLATION INSTRUCTIONS

\*\*\*Take this product to a licensed professional if you are hesitant about the installation process!\*\*\*

1. The installation may be completed with the vehicle on the ground. There is no need to remove the wheels and tires.

Remove the original track bar at both the axle and the frame. The axle-side mount is located under the spring perch. The original bolt can be removed using a 17mm socket, however, your bolt may be different. There is a flag nut on the opposite side of the track bar mount that will hold the nut as you remove the bolt. If the bolt is seized and you cannot get it loose, you may cut the bolt. Upgraded hardware, as well as a new flag nut, are supplied.

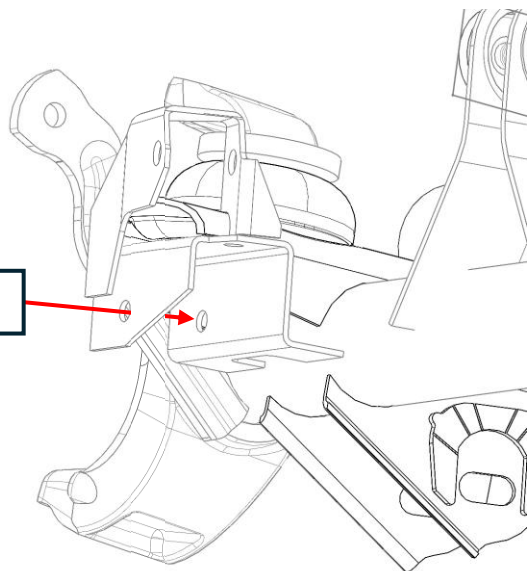

XJ axle-end track bar mount (bolt removed)



XJ frame-end track bar mount (bolt to be removed)

# INSTALLATION INSTRUCTIONS

\*\*\*Take this product to a licensed professional if you are hesitant about the installation process!\*\*\*

2. With the old front track bar completely removed, drill out the front axle track bar mount to 9/16" diameter. This will allow the upgraded, 9/16" hardware to pass through the original mount location.

Now, at the frame-end, ensure that the supplied 9/16" bolt can fit through the OEM mount. If it cannot, drill out the mount to 9/16"

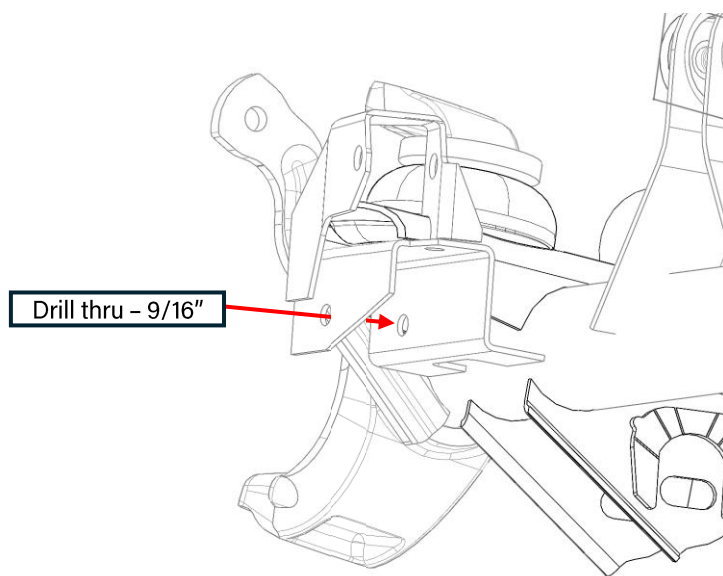

XJ axle-side track bar mount drilled out

# INSTALLATION INSTRUCTIONS

3. Determine the appropriate length of the new track bar based on your vehicle's ride height and your desired axle track. You can measure the length of the original track bar as a starting point.

Adjust the end-forging by screwing it in or out. **Measure the length from eye-to-eye, or center of bushing to center of bushing.** When the desired length is met, spin the jam nut down to the control arm to lock the forging into position.

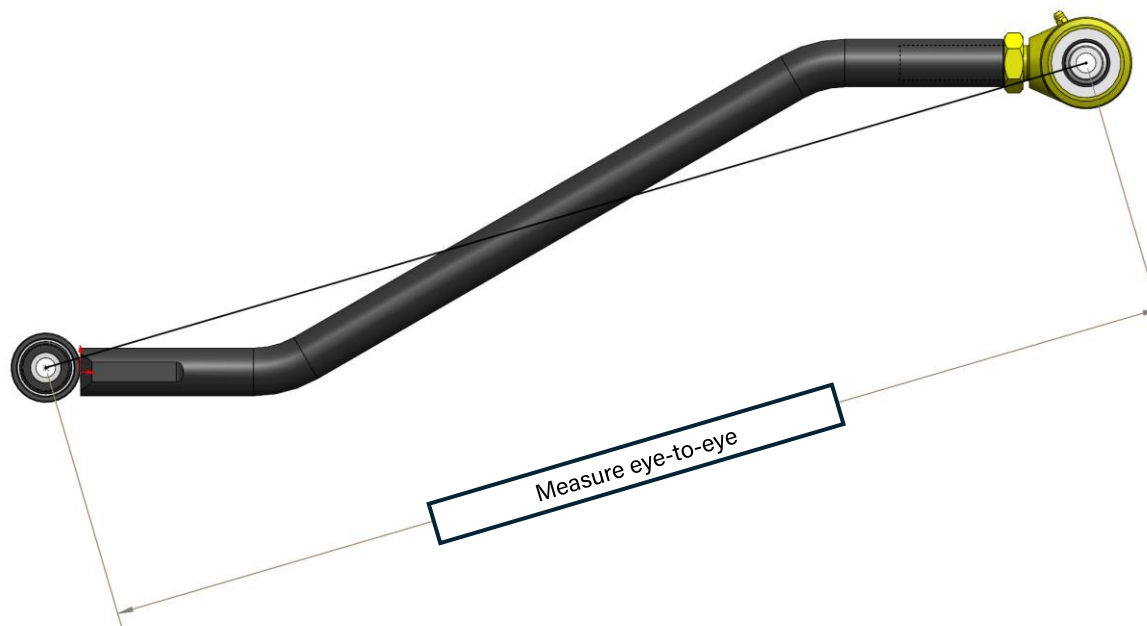

# INSTALLATION INSTRUCTIONS

4. With the track bar adjusted to an ideal length, install the track bar with the adjuster end at the bracket (frame-end). Use the supplied 9/16"-18 bolt and hardware. Use a 13/16" and 7/8" wrench. Tighten, **but do not torque yet**.

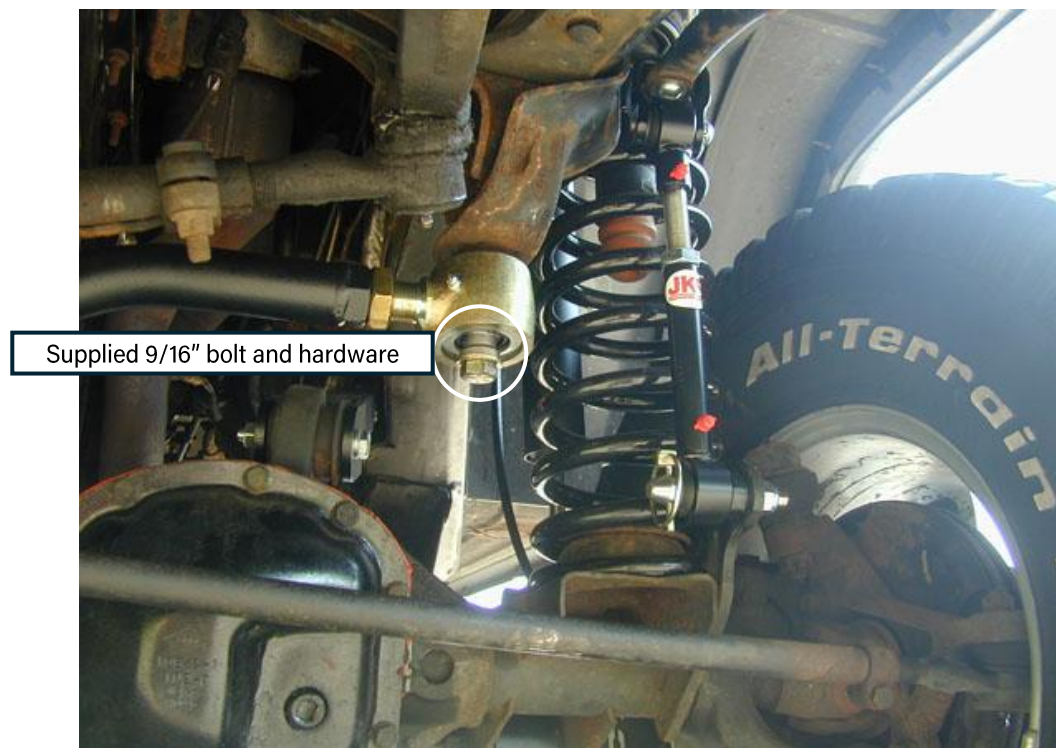

XJ with original track bar bracket and new track bar installed

# INSTALLATION INSTRUCTIONS

5. Loosely install the non-adjustable end of the track bar into the mount on the axle. Use the provided 9/16" bolt and hardware, and a 13/16" wrench with the provided flag-nut.



XJ axle mount track bar fully installed

# INSTALLATION INSTRUCTIONS

6. With the vehicle on the ground, torque both track bar bolts to 110 lb-ft. You may also want to confirm that the frame-side track bar bracket is tightened down to the frame.



XJ drop bracket and track bar fully installed and painted

\*\*\*In the photo above, a drop bracket for the frame-end track bar connection is used\*\*\*

# INSTALLATION INSTRUCTIONS

7. Tighten down the jam nut on the track bar. Use a 1-1/2" wrench or an adjustable wrench for the jam nut. Use a breaker bar to gain additional leverage. Tighten all jam nuts down as tight as humanly possible.

Please note that not all wrenches are created with the same tolerances. If your wrenches are too loose around the jam nut, Clayton Off Road offers tight, wrap-around wrenches for purchase. Please search for the wrenches using the SKU's below.



COR Wrench-ends for control arm jam nuts (COR-2500125, COR-2500100)

# INSTALLATION INSTRUCTIONS

8. The installation is now complete. Please follow the post-installation checklist below before driving your vehicle.



## POST-INSTALLATION CHECKLIST:

- Front track bar bolts torqued to 110 lb-ft (frame-side and axle-side)
- Lug nuts are torqued to the manufacturer's specification (if removed)
- Jam nuts are jammed down as tight as possible
- A professional properly aligns the vehicle for adjusting your axle track

